

ALLOY STEEL SWIVEL HOIST RINGS



Swivel Hoist Rings have full swivel and pivot action and are the ideal product for angular lift applications. They are alloy steel with a black oxide finish and they adhere to the same rigid quality standards that have been a part of Chicago Hardware's proud tradition since 1912. Individually proof tested and magnetic particle inspected. From 800 to 24,000 lb load capacities (Rated at 5:1 design factor).

- Meets or exceeds all requirements of ASME B30.26 including identification, ductility, design factor, proof load and temperature requirements.
- Material traceability available through Product Identification Code (PIC) System

Part No.	Thread Size (A)	Working Load Limit	Thread Length (C)	B	D	E	F	G	H	Torque
86004 8	5/16"-18	800	9/16"	2.67"	0.75"	0.43"	0.38"	1.84"	1-1/4"	7
86007 9	3/8"-16	1000	9/16"	2.67"	0.75"	0.43"	0.38"	1.84"	1-1/4"	12
86013 0	1/2"-13	2500	3/4"	4.78"	1.5"	0.88"	0.75"	3.52"	2-3/8"	28
86016 1	1/2"-13	2500	1"	4.78"	1.5"	0.88"	0.75"	3.52"	2-3/8"	28
86019 2	1/2"-13	2500	1-1/4"	4.78"	1.5"	0.88"	0.75"	3.52"	2-3/8"	28
86022 2	5/8"-11	4000	1"	4.78"	1.5"	0.88"	0.75"	3.52"	2-1/4"	60
86025 3	5/8"-11	4000	1-1/4"	4.78"	1.5"	0.88"	0.75"	3.52"	2-1/4"	60
86028 4	3/4"-10	5000	1"	4.78"	1.5"	0.88"	0.75"	3.52"	2-1/8"	100
86031 4	3/4"-10	5000	1-1/2"	4.78"	1.5"	0.88"	0.75"	3.52"	2-1/8"	100
86034 5	3/4"-10	7000	1"	6.52"	2.31"	1.4"	1"	5.14"	2-15/16"	100
86037 6	3/4"-10	7000	1-1/2"	6.52"	2.31"	1.4"	1"	5.14"	2-15/16"	100
86043 7	7/8"-9	8000	1-1/4"	6.52"	2.31"	1.4"	1"	5.14"	2-13/16"	160
86046 8	1"-8	10000	1-1/4"	6.52"	2.31"	1.4"	1"	5.14"	2-11/16"	230
86049 9	1"-8	10000	1-1/2"	6.52"	2.31"	1.4"	1"	5.14"	2-11/16"	230
86052 9	1"-8	10000	2-1/4"	6.52"	2.31"	1.4"	1"	5.14"	2-11/16"	230
86055 0	1-1/4"-7	15000	1-7/8"	8.73"	3.19"	1.75"	1.25"	6.5"	4-1/4"	470
86061 1	1-1/2"-6	24000	2-3/4"	12.47"	4.19"	2.25"	1.75"	8.55"	6-1/2"	800

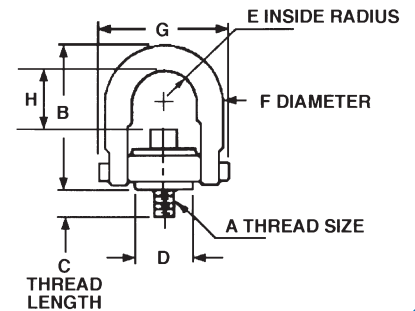

WARNING: DO NOT EXCEED SAFE WORK LOAD

DROP FORGED LIFTING EYES

Drop forged from C-1035 steel, heat treated. Available blank or threaded. Self-colored finish is standard; hot galvanized or other finishes supplied on a special basis. Used in lifting applications where larger eyes are required. When ordering prefix stock number with letter "B" (blank) or "T" (threaded) as required. Loads are based on a design factor of 5 to 1. Working loading limits for lifting eyes are based on a straight vertical lift in a gradually increasing manner, and should never be used for angular lifts.

LIFTING EYES – SELF-COLORED

Stock Number	Bail Size	Blank Part No.	Threaded Part No.	Threaded Working Load Limit
C-186	1/4"	15005 7	15505 2	860
C-187	5/16"	15010 1	15510 6	1260
C-185	3/8"	15015 6	15515 1	2200
C-181	1/2"	15020 0	15520 5	3600
C-184	5/8"	15025 5	15525 0	5200
C-188	3/4"	15030 9	15530 4	7000

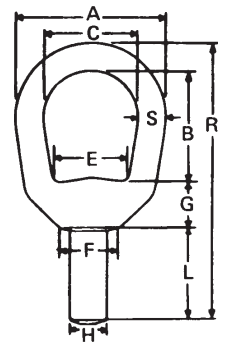

Stock Number	Shank		Dimensions – Inches								Thread Length	Weight Per 100	
	H	L	A	C	B	E	F	G	S	R		Blank	Threaded
C-186	5/16"	1"	1-1/4"	3/4"	1-1/16"	19/32"	1/2"	3/8"	1/4"	2-11/16"	7/8"	12	11
C-187	3/8"	1-1/8"	1-5/8"	1"	1-1/4"	3/4"	9/16"	1/2"	5/16"	3-3/16"	1"	22	22
C-185	1/2"	1-1/2"	2"	1-1/4"	1-1/2"	1"	13/16"	5/8"	3/8"	4"	1-3/8"	41	38
C-181	5/8"	1-3/4"	2-1/2"	1-1/2"	2"	1-3/16"	1"	11/16"	1/2"	4-15/16"	1-5/8"	81	74
C-184	3/4"	1-7/8"	3"	1-3/4"	2-3/8"	1-3/8"	1-1/8"	7/8"	5/8"	5-3/4"	1-3/4"	139	129
C-188	7/8"	2"	3-1/2"	2"	2-5/8"	1-5/8"	1-5/16"	15/16"	3/4"	6-5/16"	1-7/8"	222	214